

Driver \_\_\_\_\_ Date \_\_\_\_\_ Track \_\_\_\_\_ Event \_\_\_\_\_

**Track Condition**

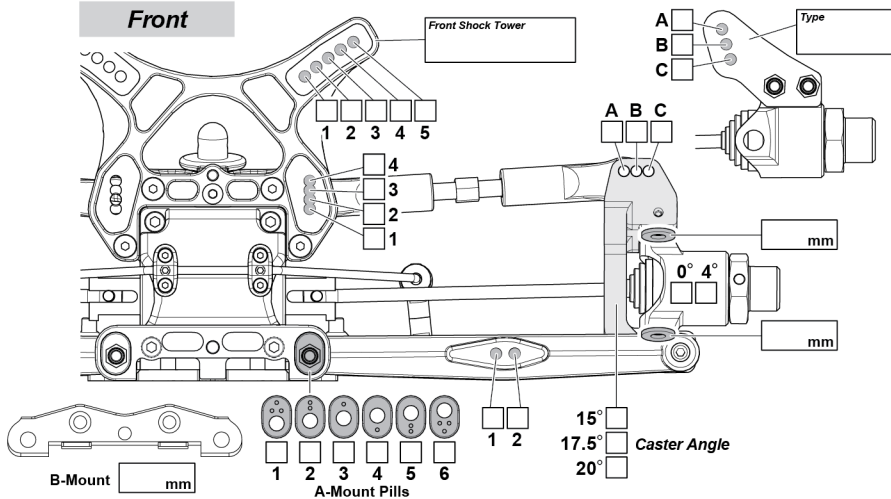

Ride Height \_\_\_\_\_

Camber Angle \_\_\_\_\_

Toe Angle \_\_\_\_\_

Sway Bar \_\_\_\_\_

Shock Length \_\_\_\_\_

Shocks	
Oil	_____
Piston	_____
Rebound	_____
Spring	_____
Notes	_____

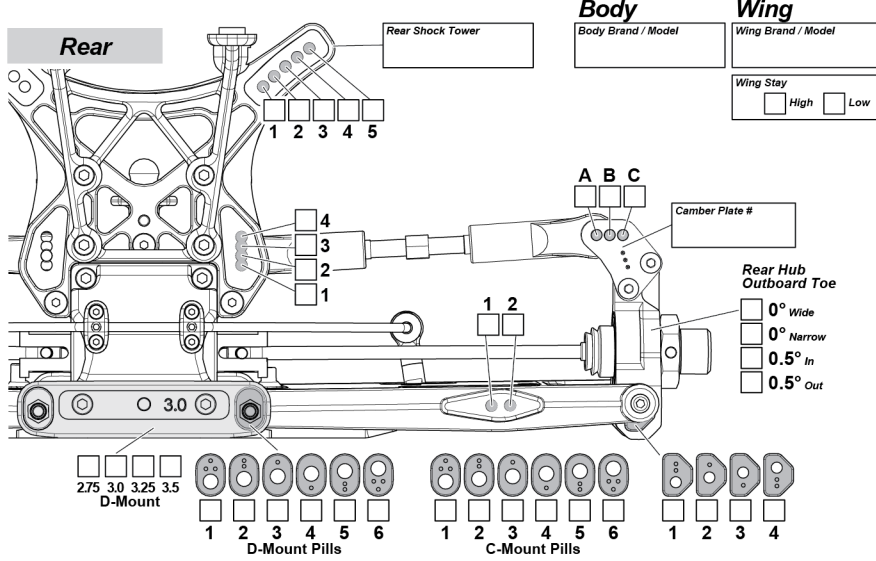
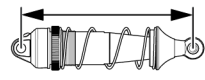

Ride Height \_\_\_\_\_

Camber Angle \_\_\_\_\_

Sway Bar \_\_\_\_\_

Shock Length \_\_\_\_\_

Shocks	
Oil	_____
Piston	_____
Rebound	_____
Spring	_____
Notes	_____

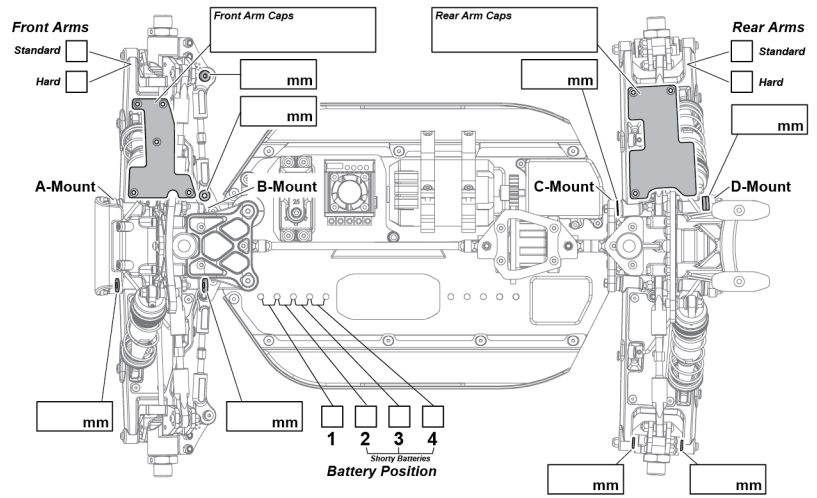
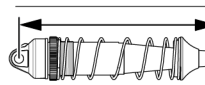

Notes \_\_\_\_\_

**Motor**

Brand / Model \_\_\_\_\_

Spur gear \_\_\_\_\_ Pinion Gear \_\_\_\_\_

**Battery**

Brand / Model \_\_\_\_\_

**ESC**

Brand / Model \_\_\_\_\_

Tires	Front	Rear
Brand	_____	_____
Compound	_____	_____
Insert	_____	_____
Wheel	_____	_____
Notes	_____	_____

Diff Oils	Front	Center	Rear
Brand	_____	_____	_____
Oil	_____	_____	_____